

All raw material,production process,electroplating must meet the requirements of EU RoHS.

REV.	ECN NO.	LOCAS.	DESCRIPTION	DATE	DESIGN
A0			RELEASE TO CUSTOMER		HANG
C					HANG

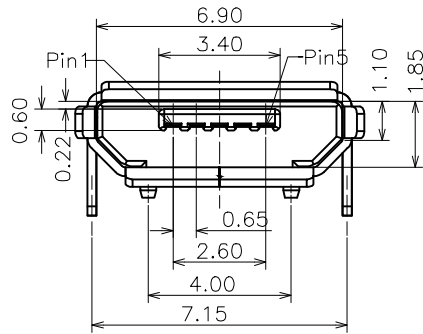
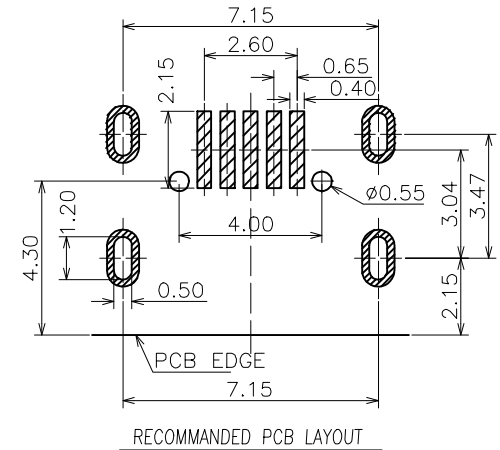
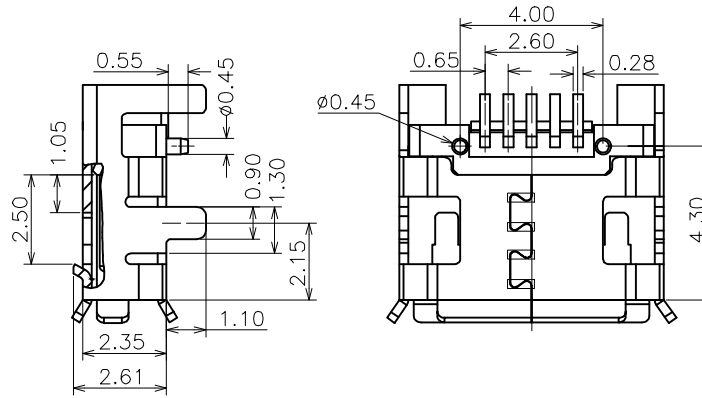
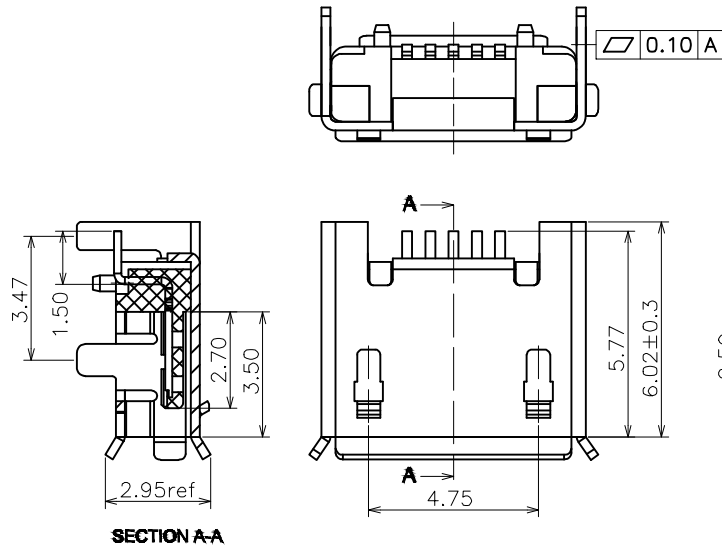

1.Material:

- 1.1 Housing: High temperature thermoplastic with g.f,UL94v-0
- 1.2 Contact: copper alloy,t=0.20mm
- 1.3 Shell: Copper Alloy/SUS304,t=0.25mm

2.Specification:

- 2.1 Current rating:1,5PIN 1.8A Max /2,3,4PIN 1A Max.
- 2.2 Dielectric withstanding voltage: 100 V(ac) for 1 min.
- 2.3 Contact resistance: 30 mΩ Max.
- 2.4 Insulation resistance: 100 MΩ Min.
- 2.5 Total mating force: 3.57 Kgf Max.
- 2.6 Total unmating force: 1.0 Kgf Min.
- 2.7 Temperature range: -30°C~80°C

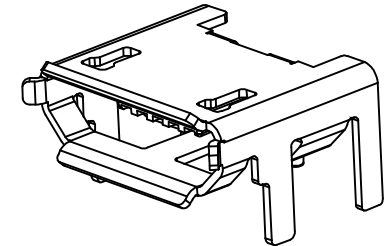

Ordering Information of Product:

UF-C2A0-04BD

①Shell:Copper Alloy

UF-C2A0-04BD-UI

②Shell:SUS304

深圳朗思达科技有限公司

DIM	TOL	DIM	TOL
X.	±0.30	X'	±4.0'
X.X	±0.25	X.X'	±3.0'
X.XX	±0.20	X.XX'	±2.0'
X.XXX	±0.10	X.XXX'	±1.0'

THIS DRAWING CONTAINS INFORMATION THAT IS PROVIDED IN CONFIDENCE OR PROPRIETARY RIGHTS AND SHOULD NOT BE USED WITHOUT WRITTEN PERMISSION

DRAW NO.		DATE	DRAW NAME:	
DESIGN	HANG	20200218	MICRO USB 5PIN 四脚加长插板7.2 有柱 卷边	
CHECK	ZHAOZZ	20200218	P/N NO. 20800046	CIB CODE:
APPROVED	RYAN	20200218	UNIT: mm	MODEL:
			SHEET: N/A	REV. C SCALE N/A