

\*All raw material,production process,electroplating must meet the requirements of EU RoHS.\*

| REV. | ECN NO. | LOCAS. | DESCRIPTION         | DATE   | DESIGN |
|------|---------|--------|---------------------|--------|--------|
| A0   |         |        | RELEASE TO CUSTOMER | 200218 | HANG   |

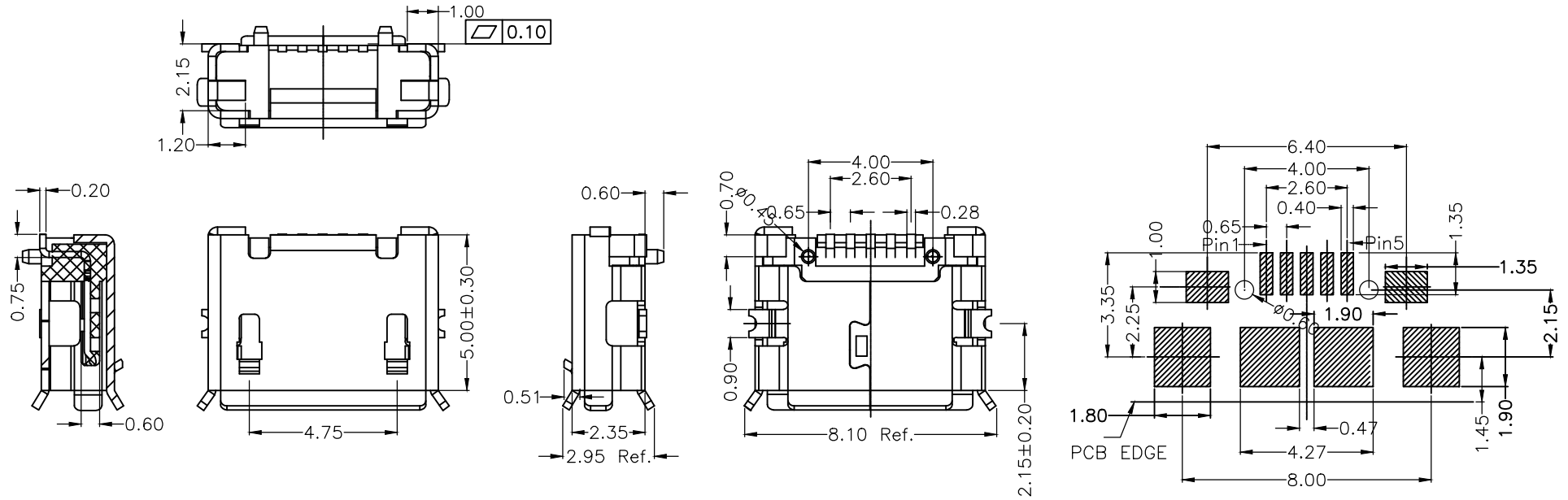

RECOMMENDED PCB LAYOUT PCB图仅供参考

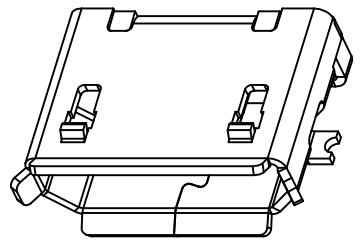

**Note:**

**1.Material:**

- 1.1 Housing: High temperature thermoplastic with g.f,UL94v-0
- 1.2 Contact: copper alloy,t=0.20mm
- 1.3 Shell: SUS304,t=0.25mm

**2.Specification:**

- 2.1 Current rating:1,5PIN 1.8A Max /2,3,4PIN 1A Max.
- 2.2 Dielectric withstanding voltage: 100 V(ac) for 1 min.
- 2.3 Contact resistance: 30 mΩ Max.
- 2.4 Insulation resistance: 100 MΩ Min.
- 2.5 Total mating force: 3.57 Kgf Max.
- 2.6 Total unmating force: 1.0 Kgf Min
- 2.7 Temperature range: -30°C~80°C

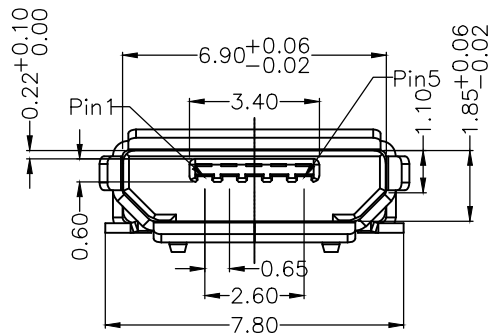

Lastar Technology CO.,LTD

|          |        |          |                         |            |
|----------|--------|----------|-------------------------|------------|
| DRAW NO. |        | DATE     | DRAW NAME:              |            |
| DESIGN   | HANG   | 20200218 | MICRO USB 5PIN 全贴 卷边 有柱 |            |
| CHECK    | ZHAOZZ | 20200218 | P/N NO. 20800005        | LSD CODE:  |
| APPROVED | RYAN   | 20200218 | UNIT: mm                | SHEET: N/A |
|          |        |          | MODEL:                  | REV. A0    |
|          |        |          | SCALE                   | N/A        |

| DIM   | TOL   | DIM    | TOL   |
|-------|-------|--------|-------|
| X.    | ±0.30 | X'     | ±4.0' |
| X.X   | ±0.25 | X.X'   | ±3.0' |
| X.XX  | ±0.20 | X.XX'  | ±2.0' |
| X.XXX | ±0.10 | X.XXX' | ±1.0' |

THIS DRAWING CONTAINS INFORMATION THAT IS PROVIDED BY LASTAR TECHNOLOGY AND SHOULD NOT BE USED WITHOUT WRITTEN PERMISSION