

All raw material,production process,electroplating must meet the requirements of EU RoHS.

REV.	ECN NO.	LOCAS.	DESCRIPTION	DATE	DESIGN
A0			RELEASE TO CUSTOMER		HANG
D					HANG

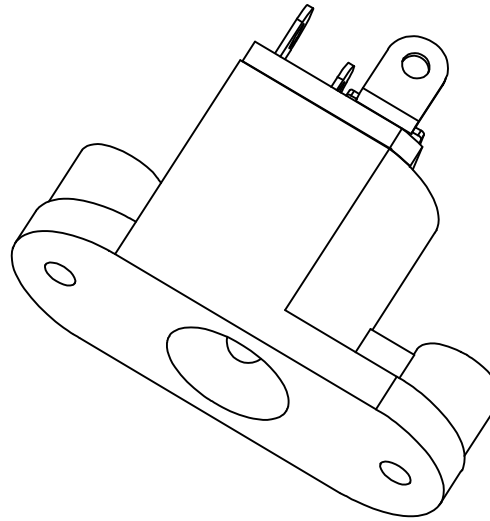
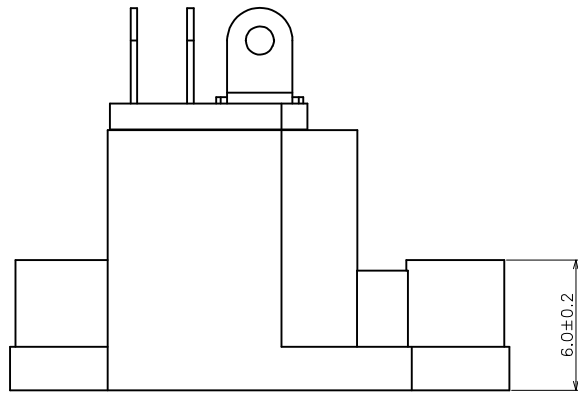

PIN	Ø2.0	Ø2.5
APPD	✓	✓

SPECIFICATION

- 1.Current Rating:0.5Amp
- 2.Operation Voltage:30V
- 3.Contact Resistance:30m Ohms Max
- 4.Insulation Resistance:100M Ohms Min
- 5.Dielectric Withstanding Voltage: 500VAC
- 6.Mating and Unmating Force:3 to 20N
- 7.Life:5000 Cycles

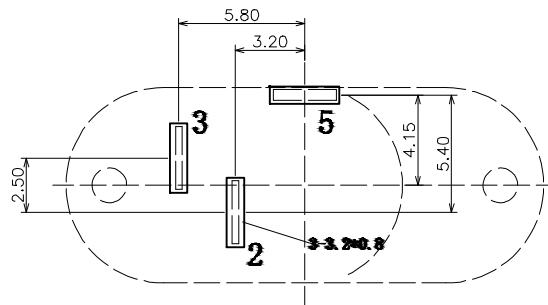
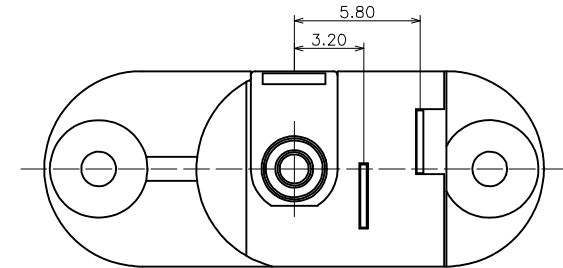
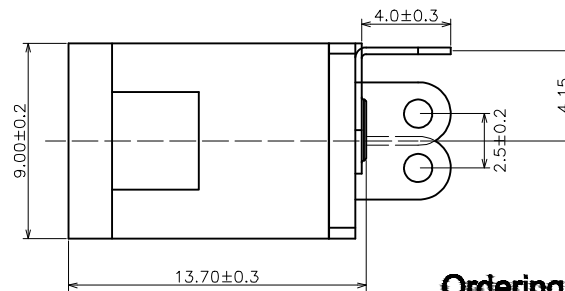
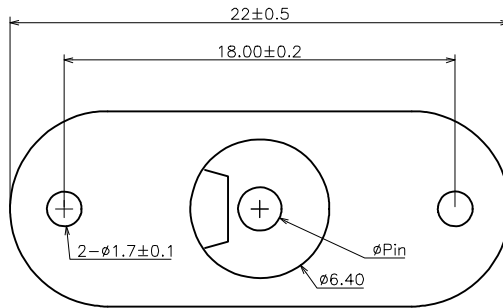

PCB Layout

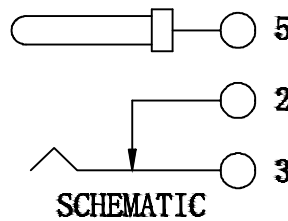

Ordering Information of Product:

DC-09018-XX

1. XX:Ø Pin (YY=20,Ø=2.0; YY=25,Ø=2.5)

深圳朗思达科技有限公司

DRAW NO.	DATE	DRAW NAME:	
DESIGN	HANG	DC座 DC-018 DIP180	
CHECK	ZHAOZZ	P/N NO. 30500089	CIB CODE:
APPROVED	RYAN	UNIT: mm	SHEET: N/A
		MODEL: REV. D SCALE N/A	

DIM	TOL	DIM	TOL
X.	±0.30	X'	±4.0'
X.X	±0.25	X.X'	±3.0'
X.XX	±0.20	X.XX'	±2.0'
X.XXX	±0.10	X.XXX'	±1.0'

THIS DRAWING CONTAINS INFORMATION THAT IS PROVIDED IN CONFIDENCE OR ELECTRONIC COULD AND SHOULD NOT BE USED WITHOUT WRITTEN PERMISSION