

\*All raw material, production process, electroplating must meet the requirements of EU RoHS.\*

REV.	ECN NO.	LOCAS.	DESCRIPTION	DATE	DESIGN
A0			RELEASE TO CUSTOMER	200218	HANG

- CURRENT RATING : 5.0A FOR Vbus PIN,  
1.25A FOR Vconn PIN,  
0.25A FOR OTHER PINS.
- VOLTAGE RATING : 20V DC MAX.
- CONTACT RESISTANCE : 40mΩ.
- INSULATION RESISTANCE : 100MΩ MIN.
- DIELECTRIC WITHSTANDING VOLTAGE : 100 VAC MIN.
- OPERATING TEMPERATURE : -40°C TO +85°C.
- MATING FORCE : 5~20N.
- UNMATING FORCE : 8~20N.
- DURABILITY : 10,000 CYCLES.

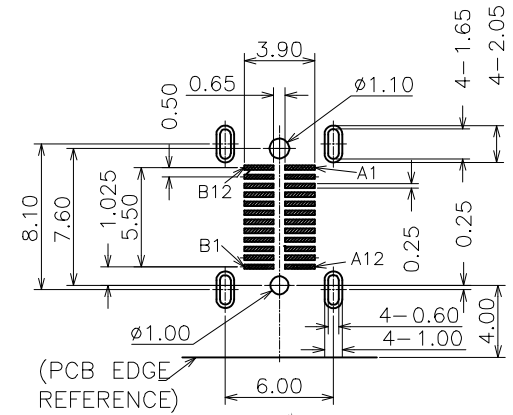
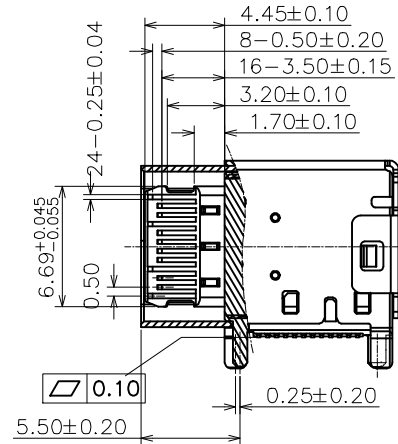
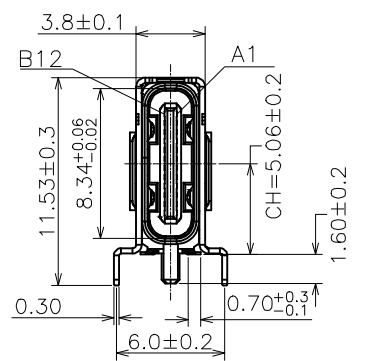
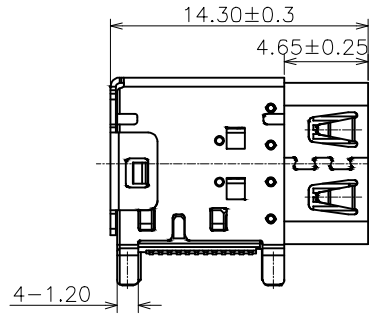
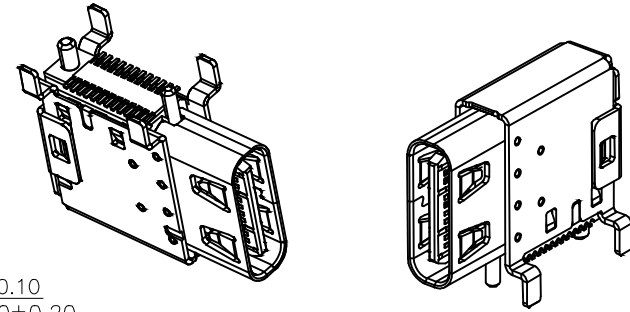
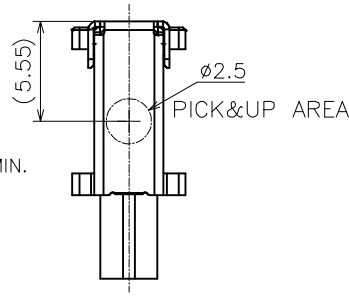

PCB Layout

A1	GND	B12	GND
A2	SSTXP1	B11	SSRXP1
A3	SSTXN1	B10	SSRXN1
A4	VBUS	B9	VBUS
A5	CC1	B8	SBU2
A6	DP1	B7	DN2
A7	DN1	B6	DP2
A8	SBU1	B5	CC2
A9	VBUS	B4	VBUS
A10	SSRXN2	B3	SSTXN2
A11	SSRXP2	B2	SSTXP2
A12	GND	B1	GND
PIN	SIGNAL NAME	PIN	SIGNAL NAME

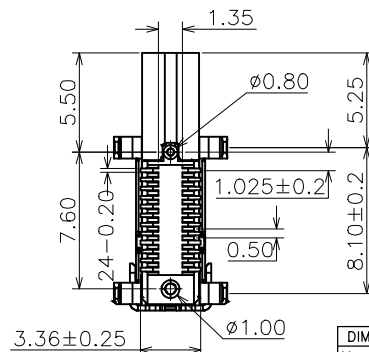

DIM	TOL	DIM	TOL
X.	±0.30	X'	±4.0'
X.X	±0.25	X.X'	±3.0'
X.XX	±0.20	X.XX'	±2.0'
X.XXX	±0.10	X.XXX'	±1.0'

深圳朗思达科技有限公司

DRAW NO.		DATE	DRAW NAME: TYPE C 母座 24PIN 侧立贴 四脚插 14.3	
DESIGN	HANG	20200218	P/N NO. 21000291	CIB CODE:
CHECK	ZHAOZZ	20200218	UNIT: mm	SHEET: N/A
APPROVED	RYAN	20200218	MODEL: REV. A0 SCALE N/A	

THIS DRAWING CONTAINS INFORMATION THAT IS PROVIDED BY DONOR OR ELECTRONIC SOLUTION AND SHOULD NOT BE USED WITHOUT WRITTEN PERMISSION