

NC-Cap/super-QR/PSR-II™ CV/CC Power Switch

FEATURES

- ◆ $\pm 5\%$ Constant Voltage Regulation at Universal AC input
- ◆ High precision Constant Current Regulation at Universal AC input
- ◆ Primary-side Sensing and Regulation Without TL431 and Opto-coupler
- ◆ Programmable CV and CC Regulation
- ◆ Built-in Primary winding inductance compensation
- ◆ Programmable Cable Drop Compensation
- ◆ Driver BJT Switch
- ◆ Ultra Low Start-up Current (Typ. $1\mu\text{A}$)
- ◆ VDD Over Voltage Protection
- ◆ Built-in Feedback Loop Open Protection
- ◆ Built-in Short Circuit Protection
- ◆ Built-in Leading Edge Blanking (LEB)
- ◆ Cycle-by-Cycle Current Limiting
- ◆ VDD Under Voltage Lockout with Hysteresis (UVLO)

APPLICATIONS
Low Power AC/DC offline SMPS for

- ◆ Cell Phone Charger
- ◆ Digital Cameras Charger
- ◆ Small Power Adapter
- ◆ Auxiliary Power for PC, TV etc.
- ◆ Linear Regulator/RCC Replacement

GENERAL DESCRIPTION

SF6051L is a high performance offline PSR controller for low power AC/DC charger and adapter applications. It operates in primary-side sensing and regulation. Consequently, opto-coupler and TL431 could be eliminated. Proprietary Constant Voltage (CV) and Constant Current (CC) control is integrated as shown in the figure 1 below.

In CC control, the current and output power setting can be adjusted externally by the sense resistor R_s at CS pin. In CV control, PFM operations are utilized to achieve high performance and high efficiency. In addition, good load regulation is achieved by the built-in cable drop compensation. The chip consumes very low operation current (typical $300\mu\text{A}$), it can achieve less than 50mW standby power to meet strict standby power standard.

SF6051L offers comprehensive protection coverage with auto-recovery features including Cycle-by-Cycle current limiting, VDD over voltage protection, feedback loop open protection, short circuit protection, built-in leading edge blanking, VDD under voltage lockout (UVLO), etc.

SF6051L is available SOP7 packages.

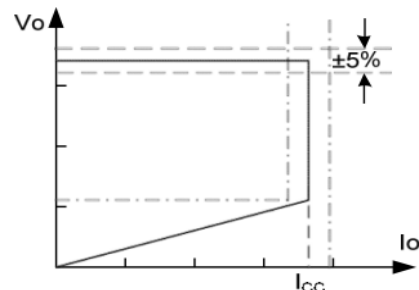
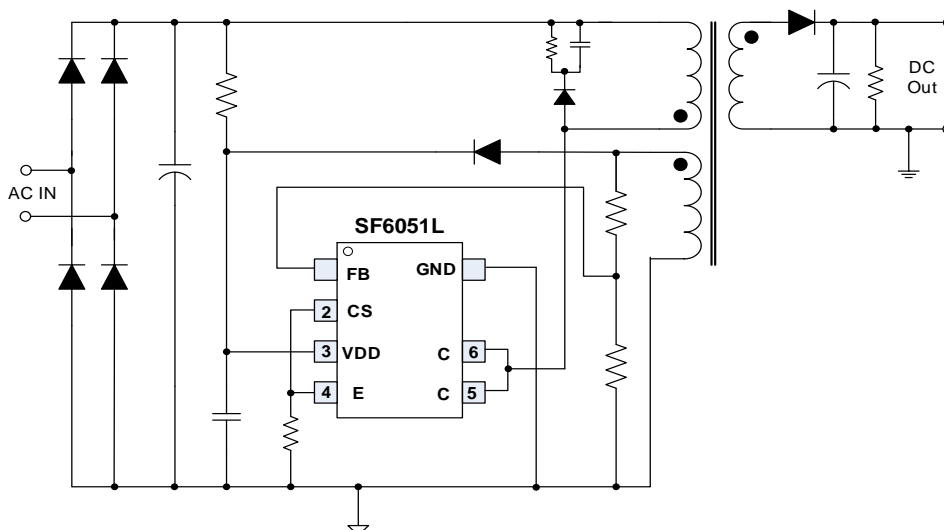
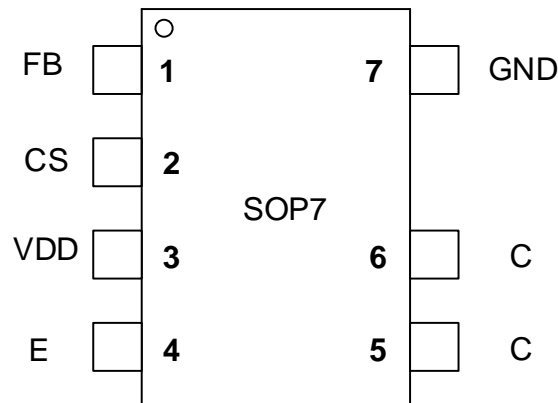

Fig.1. Typical CC/CV Curve

TYPICAL APPLICATION

Pin Configuration

Ordering Information

| Part Number | Top Mark | Output Power ⁽¹⁾ | Package | | Tape & Reel |
|-------------|-----------|-----------------------------|----------|-------|-------------|
| | | 110VAC~264VAC | | | |
| SF6051LTGT | SF6051LTG | 5V ≤ 1.9A | SOP7 (*) | Green | Yes |

Note 1. The Max. output power is limited by junction temperature

Note 2. 230VAC or 100/115VAC with doublers

Note 3. Do not operate at the chip surface temperature higher than 135 °C.

(*) MSL(Moisture Sensitivity Level) is level 3. Absorbed moisture could be sensitive to damage during solder reflow, so it's recommended to take floor life into consideration, according to IPC/JEDEC J-SMD-020E(Moisture/Reflow Sensitivity Classification for Non-hermetic Surface Mount Devices).

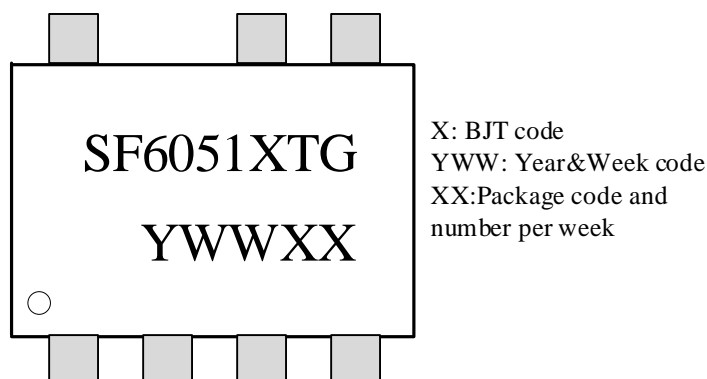
Marking Information

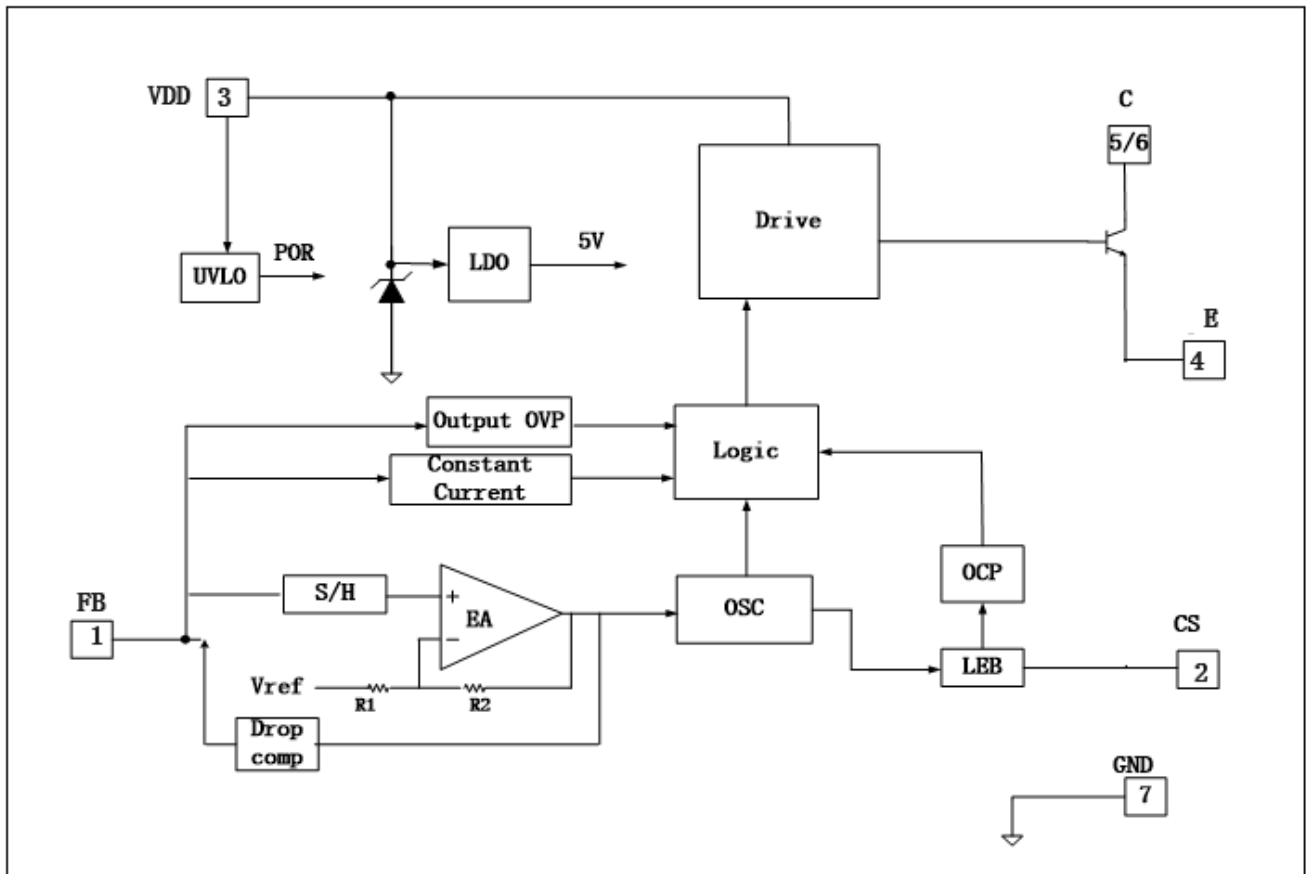
Block Diagram

Pin Description

| Pin Num | Pin Name | I/O | Description |
|---------|----------|-----|--|
| 1 | FB | I | The voltage feedback from auxiliary winding. Connected to resistor divider from auxiliary winding reflecting output voltage. |
| 2 | CS | I | Current sense pin. |
| 3 | VDD | I | IC power supply pin. |
| 4 | E | O | High voltage power BJT emitter pin. |
| 5-6 | C | O | High voltage power BJT collector pin. |
| 7 | GND | P | Ground |

Recommended Operation Conditions (Note 1)

| Parameter | Value | Unit |
|-------------------------------|-----------|------|
| Supply Voltage, VDD | 9 to 18 | V |
| Operating Ambient Temperature | -20 to 85 | °C |
| Maximum Switching Frequency | 70K | Hz |

Absolute Maximum Ratings (Note 2)

| Parameter | Value | Unit |
|--|---------------|----------|
| VDD DC Supply Voltage | -0.3V to 30V | V |
| VDD DC Clamp Current | 10 | mA |
| CS voltage range | -0.3 to 7 | V |
| FB voltage range | -0.3 to 7 | V |
| Collector to Base Voltage | 850 | V |
| Package Thermal Resistance (SOP-7) | θ_{JA} | 120 °C/W |
| | θ_{JC} | 60 °C/W |
| Maximum Junction Temperature | 150 | °C |
| Operating Temperature Range | -20 to 85 | °C |
| Storage Temperature Range | -55 to 150 | °C |
| Lead Temperature (Soldering, 10sec.) | 260 | °C |
| ESD Capability, HBM (Human Body Model) | 2 | kV |
| ESD Capability, MM (Machine Model) | 250 | V |

ELECTRICAL CHARACTERISTICS

 (T_A = 25°C, VDD=16V, if not otherwise noted)

| Symbol | Parameter | Test Conditions | Min | Typ | Max | Unit |
|---|--|--------------------------------------|--|------|------|------|
| Supply Voltage (VDD) Section | | | | | | |
| I_Startup | VDD Start up Current | VDD =16V | | 3 | 5 | uA |
| I_static | Static current | VDD=20V | | 300 | 400 | uA |
| UVLO(OFF) | VDD Under Voltage Lockout Exit (Startup) | | 15 | 16.5 | 18 | V |
| UVLO(ON) | VDD Under Voltage Lockout Enter | | 5.5 | 6 | 6.5 | V |
| VDD_OVP | VDD Over Voltage Protection trigger | | 25 | 27 | 29 | V |
| Feedback Input Section(FB Pin) | | | | | | |
| V _{FB_EA_Ref} | Internal Error Amplifier(EA) reference input | | 1.97 | 2.0 | 2.03 | V |
| T _{pause_min} | Minimum OFF time | | | 2 | | uSec |
| V _{FB_Short} | Output Short Circuit Threshold | | | 0.4 | | V |
| T _{FB_Short} | Output Short Circuit Debounce Time | | | 50 | | mSec |
| T _{CC/T_{DEM}} | Ratio between switching period in CC mode and demagnetization time | | | 7/4 | | |
| I _{cable_max} | Max Cable compensation current | | | 50 | | uA |
| Current Sense Input Section (CS Pin) | | | | | | |
| T _{blanking} | CS Leading Edge Blanking Time | | | 500 | | nSec |
| V _{th_OC_max} | Max. Current limiting threshold | | 485 | 500 | 515 | mV |
| T _{D_OC} | OCP propagation delay | From OCP comparator to base drive | | 100 | | nSec |
| Power BJT Section | | | | | | |
| BV _{CBO} | SF6051L | Collector-base breakdown voltage | I _C =1mA | 700 | | V |
| BV _{CEO} | SF6051L | Collector-emitter breakdown voltage | I _C =10mA | 400 | | V |
| BV _{EBO} | SF6051L | Emitter- base breakdown voltage | I _E =1mA | 9 | | V |
| V _{CESAT} | SF6051L | Collector Emitter Saturation Voltage | I _C =0.5A, I _B =0.1A | | 0.4 | V |
| | | | I _C =1.5A, I _B =0.5A | | 1.0 | |
| h _{FE} | SF6051L | DC Current Gain | V _{CE} =5V, I _C =0.2A | 20 | 30 | |

Note 1. Stresses beyond those listed under "Absolute Maximum Ratings" may cause permanent damage to the device. These are stress ratings only, and functional operation of the device at these or any other conditions beyond those indicated in the operational sections of the specifications is not implied. Exposure to absolute maximum rating conditions for extended periods may affect device reliability.

Note 2. The device is not guaranteed to function outside its operating conditions.

OPERATION DESCRIPTION

SF6051L is a cost effective PSR controller optimized for off-line low power AC-DC applications including battery chargers, it operates in primary side sensing and regulation, thus opto-coupler and TL431 are not required. Proprietary built-in CV and CC control can achieve high precision CC/CV control meeting most charger application requirements.

◆ Startup current and Start up control

Startup current of SF6051L is designed to be very low so that VCC could be charged up above UVLO threshold and starts up quickly. A large value startup resistor can therefore be used to minimize the power loss in application.

◆ Operating Current

The Operating current of SF6051L is as low as 300μA. Good efficiency and very low standby power (less than 50mW) is achieved with the low operating current.

◆ CC/CV Operation

SF6051L is designed to produce good CC/CV control characteristic as shown in the Figure 1. In charger applications, a discharged battery charging starts in the CC portion of the curve until it is nearly full charged and smoothly switches to operate in CV portion of the curve. The CC portion provides output current limiting. In CV operation, the output voltage is regulated through the primary side control. In CC operation mode, SF6051L will regulate the output current constant regardless of the output voltage drop.

◆ Principle of Operation

To support SF6051L proprietary CC/CV control, system needs to be designed in DCM mode for fly-back system(Refer to Typical Application Circuit). In the DCM fly-back converter, the output voltage can be sensed via the auxiliary winding. During BJT turn-on time, the load current is supplied from the output filter capacitor, Cout. The current in the primary winding ramps up. When BJT turns off, the energy stored in the primary winding is transferred to the secondary side such that the current in the secondary winding is

$$I_s = \frac{N_s}{N_p} \times I_p \quad (1)$$

The auxiliary voltage reflects the output voltage as shown in Figure.2 and it is given by

$$V_{AUX} = \frac{N_{AUX}}{N_s} \times (V_o + \Delta V) \quad (2)$$

Where ΔV indicates the drop voltage of the output Diode.

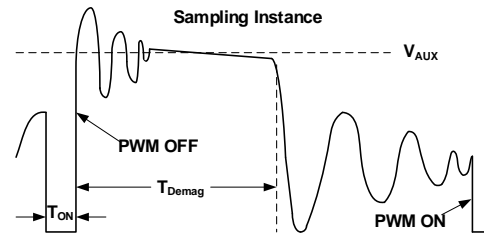

Figure 2. Auxiliary voltage waveform

Via a resistor divider connected between the auxiliary winding and FB (pin 1), the auxiliary voltage is sampled at the middle of the demagnetization and it is held until the next sampling. The sampled voltage is compared with Vref (2.0V) and the error is amplified. The error amplifier output reflects the load condition and controls the switching off time to regulate the output voltage, thus constant output voltage can be achieved.

When the sampled voltage is below Vref and the error amplifier output reaches its minimum, the switching frequency is controlled by the sampled voltage to regulate the output current, thus the constant output current can be achieved.

◆ Adjustable CC point and Output Power

In SF6051L, the CC point and maximum output power can be externally adjusted by external current sense resistor Rs at CS pin as illustrated in typical application diagram. The larger Rs, the smaller CC point is, and the smaller output power becomes, and vice versa as shown in Figure.3.

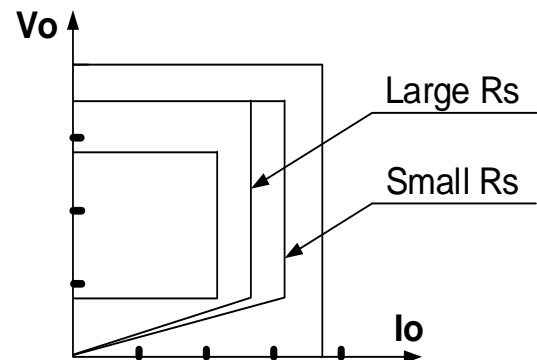

Figure 3. Adjustable output power by changing Rs

◆ Operation switching frequency

The switching frequency of SF6051L is adaptively controlled according to the load conditions and the operation modes.

For fly-back operating in DCM, The maximum output power is given by

$$P = \frac{\eta}{2} \times L_m \times I_{pk}^2 \times f_s = V_o \times I_o \quad (3)$$

Where L_m indicate the inductance of primary winding and I_{pk} is the peak current of primary winding.

Refer to the equation 3, the change of the primary winding inductance results in the change of the maximum output power and the constant output current in CC mode. To compensate the change from variations of primary winding inductance, the switching frequency is locked by an internal loop such that the switching frequency is

$$f_s \times T_{dem} = 4/7 \quad (4)$$

Since T_{Dem} is inversely proportional to the inductance, as a result, the product L_m and F_s is constant, thus the maximum output power and constant current in CC mode will not change as primary winding inductance changes.

Up to $\pm 10\%$ variation of the primary winding inductance can be compensated.

◆ Programmable Cable drop Compensation

In SF6051L, cable drop compensation is implemented to achieve good load regulation. An offset voltage is generated at FB pin by an internal current flowing into the resistor divider. The current is proportional to the switching off time, as a result, it is inversely proportional to the output load current, thus the drop due to the cable loss can be compensated. As the load current decreases from full-load to no-load, the offset voltage at FB will increase. It can also be programmed by adjusting the resistance of the divider to compensate the drop for various cable lines used.

The percentage of maximum compensation is

$$\frac{\Delta V}{V_{out}} = \frac{I_{comp_cable} * (R1 // R2) * 10^{-6}}{2} * 100\%$$

ΔV is load compensation voltage and V_{out} is the output voltage.

For example: $R1 // R2 = 3k\Omega$, the percentage of maximum compensation is

$$\frac{\Delta V}{V_{out}} = \frac{45 \times 3000 \times 10^{-6}}{2} \times 100\% = 6.75\%$$

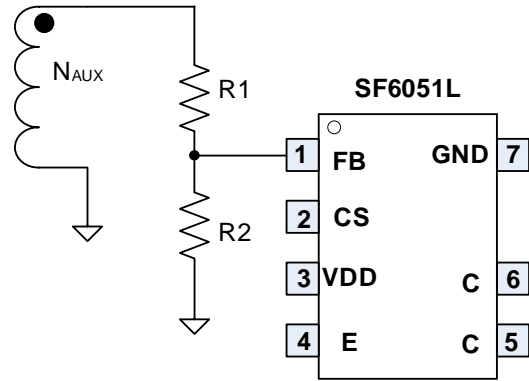

Figure 4.

◆ Current Sensing and Leading Edge Blanking

Cycle-by-Cycle current limiting is offered in SF6051L. The switch current is detected by a sense resistor into the CS pin. An internal leading edge blanking circuit chops off the sensed voltage spike at initial power BJT on state so that the external RC filtering on sense input is no longer needed.

◆ Base Drive

The drive is a push pull stage with supply voltage V_{IN} . It provides the driving current for the external power bipolar transistor. The output signal is current limit to I_{s_max} (typical 50mA).

◆ Protection Control

Good power supply system reliability is achieved with its rich protection features including Cycle-by-Cycle current limiting (OCP), VCC over Voltage protection, feedback loop open protection, short circuit protection and Under Voltage Lockout on VCC (UVLO). VCC is supplied by transformer auxiliary winding output. The output of SF6051L is shutdown when V_{IN} drops below UVLO(ON) and the power converter enters power on start-up sequence thereafter.

PACKAGE MECHANICAL DATA

SOIC-7

Unit: mm(inch)

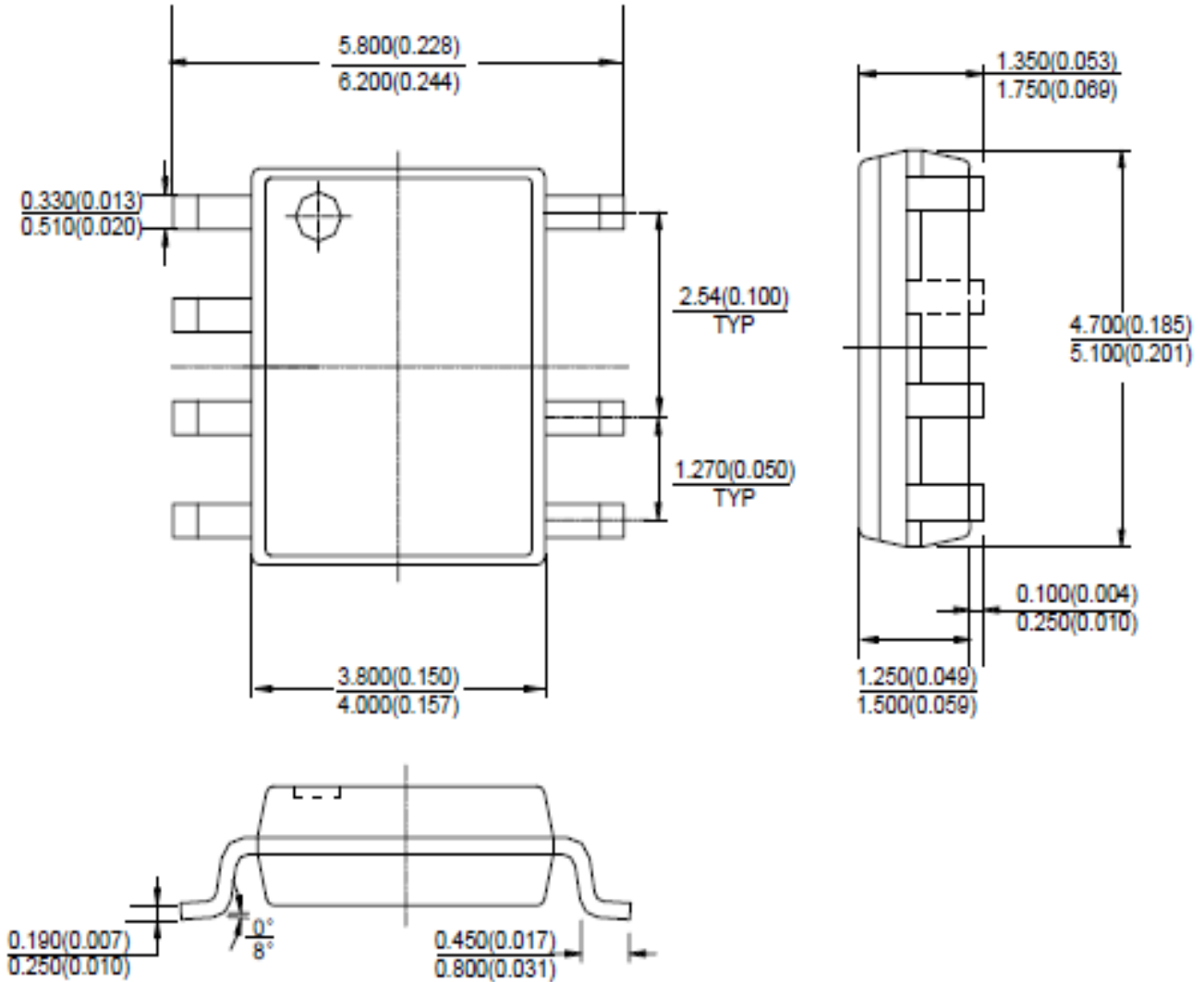

Note: Eject hole, oriented hole and mold mark is optional.

IMPORTANT NOTICE

SiFirst Technology Nanhai, Ltd (SiFirst) reserves the right to make corrections, modifications, enhancements, improvements and other changes to its products and services at any time and to discontinue any product or service without notice. Customers should obtain the latest relevant information before placing orders and should verify that such information is current and complete.

SiFirst warrants performance of its hardware products to the specifications applicable at the time of sale in accordance with SiFirst's standard warranty. Testing and other quality control techniques are used to the extent SiFirst deems necessary to support this warranty. Except where mandated by government requirements, testing of all parameters of each product is not necessarily performed.

SiFirst assumes no liability for application assistance or customer product design. Customers are responsible for their products and applications using SiFirst's components. To minimize the risks associated with customer products and applications, customers should provide adequate design and operating safeguards.

Reproduction of SiFirst's information in SiFirst's data books or data sheets is permissible only if reproduction is without alteration and is accompanied by all associated warranties, conditions, limitations, and notices. Reproduction of this information with alteration is an unfair and deceptive business practice. SiFirst is not responsible or liable for such altered documentation. Information of third parties may be subject to additional restrictions.

Resale of SiFirst's products or services with statements different from or beyond the parameters stated by SiFirst for that product or service voids all express and any implied warranties for the associated SiFirst's product or service and is an unfair and deceptive business practice. SiFirst is not responsible or liable for any such statements.

SiFirst's products are neither designed nor intended for use in military applications. SiFirst will not be held liable for any damages or claims resulting from the use of its products in military applications.

SiFirst's products are not designed to be used as components in devices intended to support or sustain human life. SiFirst will not be held liable for any damages or claims resulting from the use of its products in medical applications.