

1

2

3

4

| REV. | ECN NO. / DESCRIPTION | DATE |
|------|-----------------------|------------|
| D | R180626 | 2020.09.22 |

F

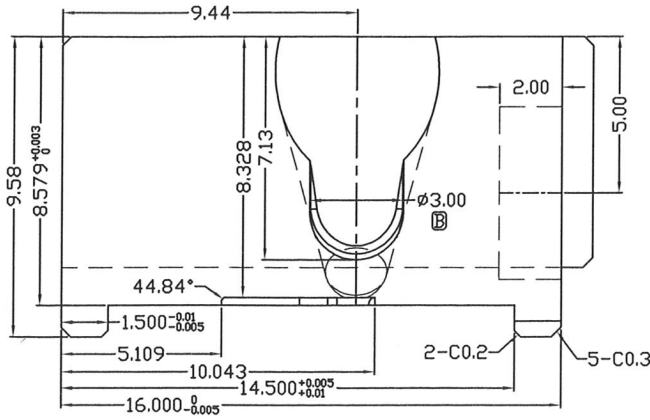

注：
 所有磨床清角 ≤ 0.02
 放電加工Ra: 0.2
 放電清角 ≤ 0.03
 放電不能有炸邊、孔洞、積碳、倒扣、亮印、刮痕
 零件不能塗保護油，零件單個包裝防止碰撞
 客戶要求外觀面放電加工 λ VDI-18=RA: 0.75
 重點澆口內部一定要鍍到Crosscut
 零件所有面上鍍0.001 \sim 0.0015mm
 現電鍍合格供應商有如下：
 表面鍍Crosscut

E

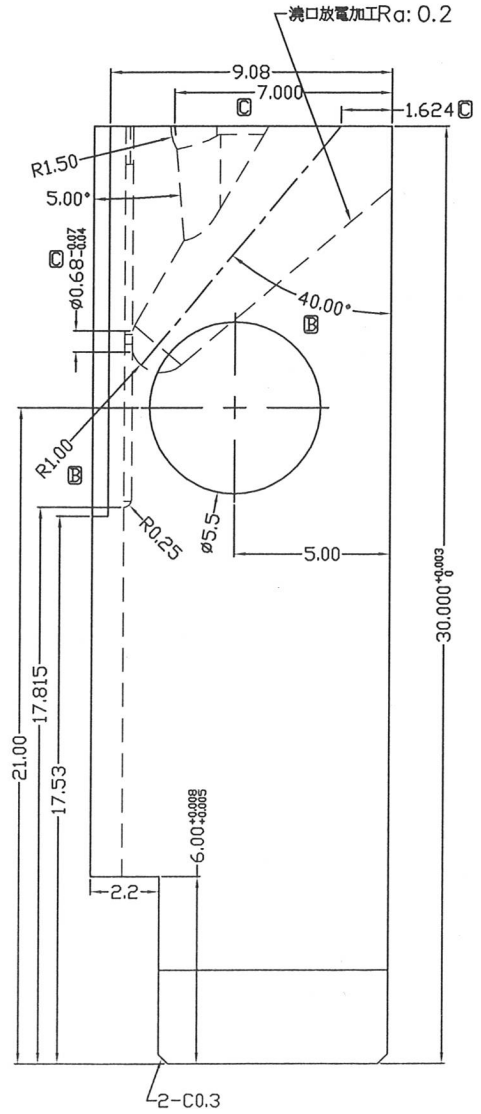
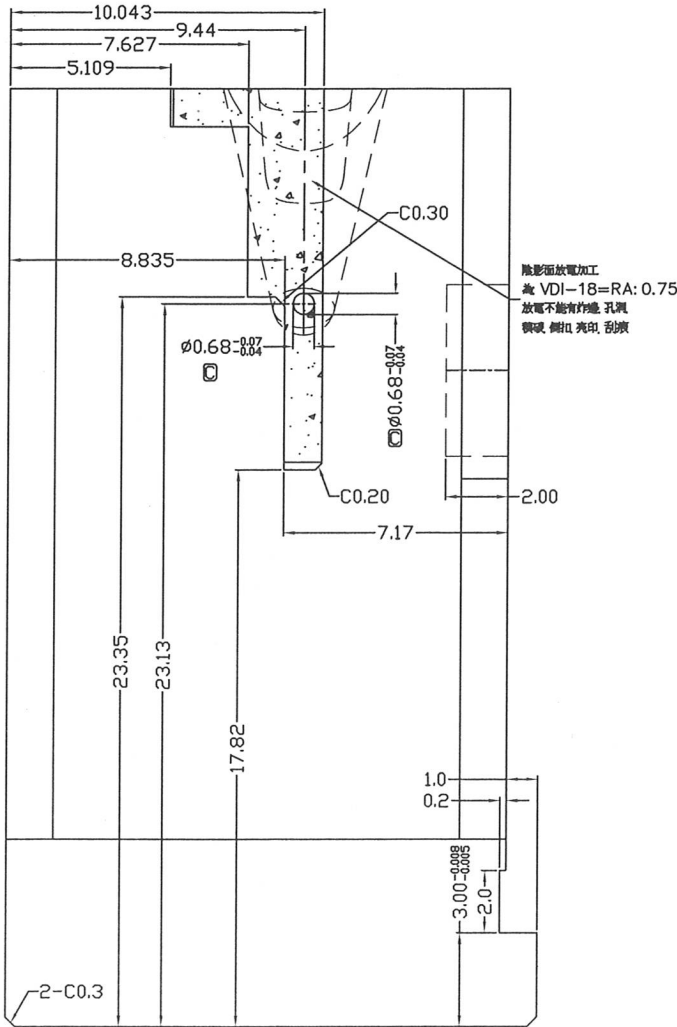

D

C

B

| | | | | | | | | |
|-------------------------------------|--------------------------------------|-------------------------------------------|---------------------------|----------------------------------|--|----------------|---------------------|-----|
| GENERAL TOLERANCES UNLESS SPECIFIED | | MATERIAL Unimax | PART NO. BSATS030-P001 | CAYMAN MOULD TECHN. CO.,LTD | | | | |
| LINEAR .X ± 0.05 | ANGLE X. $^{\circ} \pm 1^{\circ}$ | FINISH HRC52 $^{\circ}$ ~56 $^{\circ}$ | APPROVED BY | TITLE SATA 24PINPlug 塑膠主體 公模仁 | | | | |
| .XX ± 0.01 | .X. $^{\circ} \pm 0.5^{\circ}$ | UNITS MM | CHECKED BY | DWG NO. 034 | | | | |
| .XXX ± 0.005 | .XX. $^{\circ} \pm 0.1^{\circ}$ | SIZE A4 | Q'TY 4 | DRAWN BY BILL | | SHEET 2 / 1 | SCALE 1 : 0.23 D | REV |
| .XXXX ± 0.002 | .XXX. $^{\circ} \pm 0.05^{\circ}$ | | | | | | | |

1

2

3

4

A

A