

1

2

3

4

REV.	ECN NO. / DESCRIPTION	DATE

注意:

1/ 周邊倒角為0.3mm.

2/ 帶* 處清角<0.03mm.

3/ 放電部位需求<Ra0.30. 參考3D加工.

4/ 陰影部位降面0.008~0.012mm

并甩刀深0.20mm.

零件鍍鈦1u

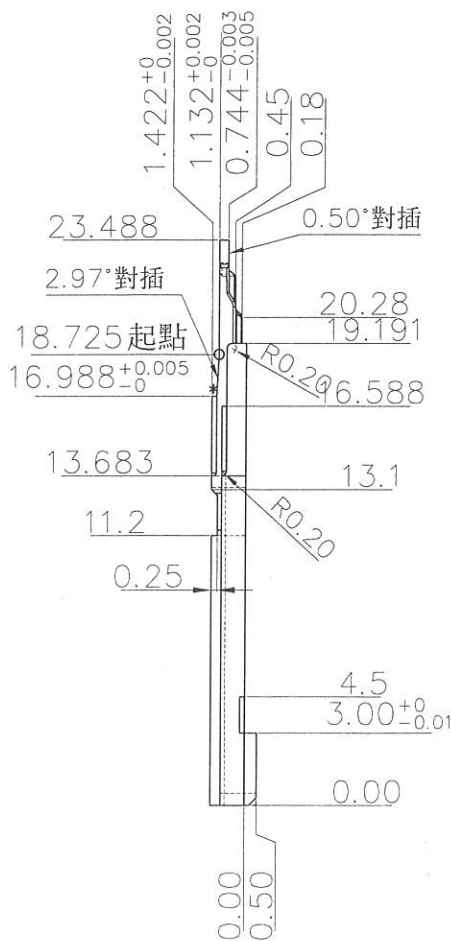
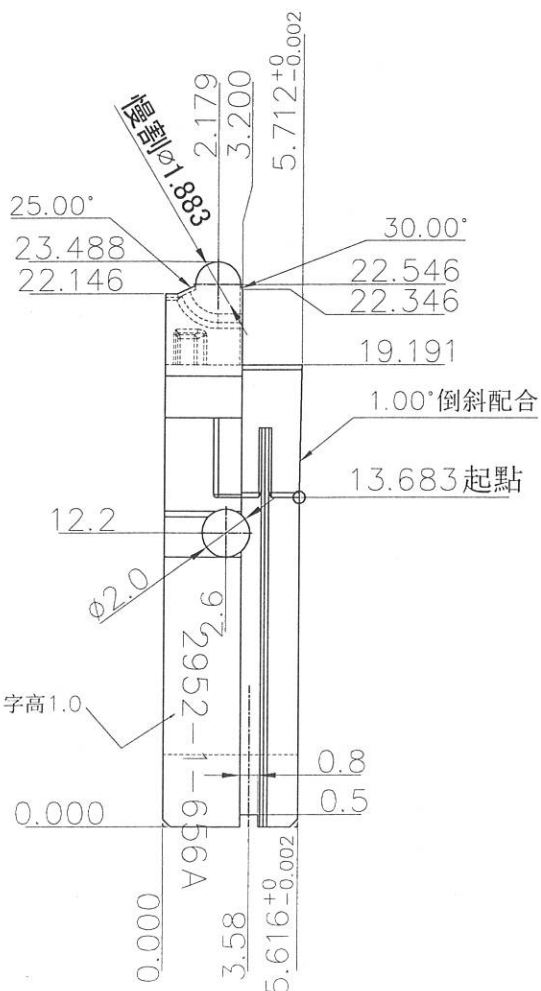
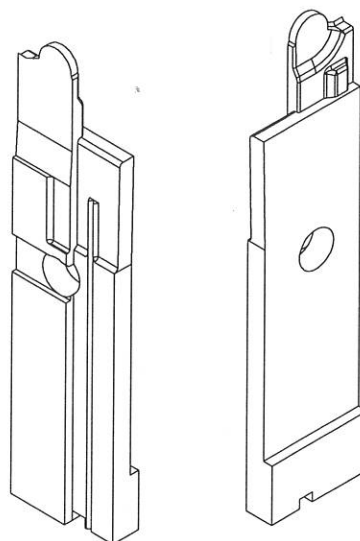
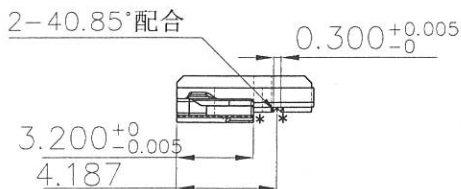

A

A

GENERAL TOLERANCES UNLESS SPECIFIED		MATERIAL ASSAB_VIKING(超深冷)	PART NO. BDR50027C-P001		CAYMAN MOULD TECHN. CO.,LTD			
LINEAR .X ±0.05	ANGLE X.° ±1°	FINISH HRC52~54°	APPROVED BY		TITLE DDR5 SMT Main mould of narrow ear metal retaining wall CAVITY INSERT			
.XX ±0.01	X.° ±0.5°	UNITS MM	CHECKED BY		DWG NO. 656			
.XXX ±0.005	.XX° ±0.1°	SIZE A4	Q'TY 5	DRAWN BY BILL	20-12-26		SHEET 1 / 1	
.XXXX ±0.002	.XXX° ±0.05°					SCALE 1:0.3		REV A

1

2

3

4