

# Dieran

## 东莞市地安电子科技有限公司 DONGGUAN CITY DIERAN ELECTRONICS CO.,LTD

### REVISION RECORD

REV.	DESCRIPTION	ECN NO.	APPROVED	DATE

项目/参数/认证				
额定电压 (Rated Voltage) [V]	450	450	450	300
额定电流 (Rated Current) [A]	24	24	24	15
额定线经平方 (Wire Range mm <sup>2</sup> )	0.2-2.5	0.2-2.5	0.2-2.5	0.2-2.5
额定线经线号 (Wire Range AWG)	24-14	24-14	24-14	24-14
冲击电压 Impulse withstand voltage	4 (KV)			
剥线长度 (Stripping Length) [mm]	8-9 (mm)			
绝缘材料 (Insulation Material)	PA66 UL94V-0			
导体材料 (Contact Material)	黄铜 (brass)			
导体表面镀层 (Contactive Coating)	镀锡 (Dumb tin)			
间距 (Pitch) [mm]	5.0			
级数 (Poles) [P]	2-32P			
工作温度 (Operating temperatur) [°C]	-40°C ~ +105°C			
焊锡温度 (Soldering temperature) [°C]	250°C/5S			

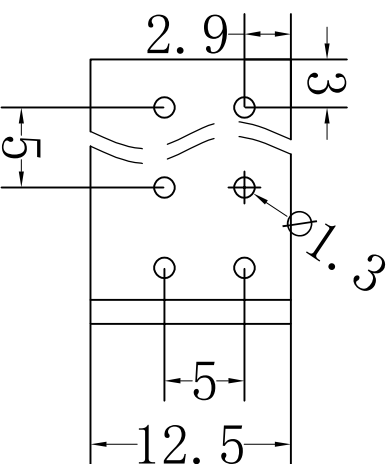
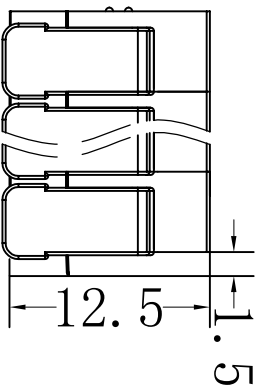
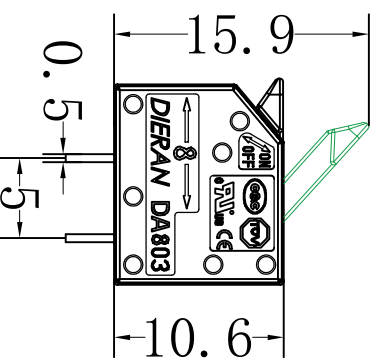
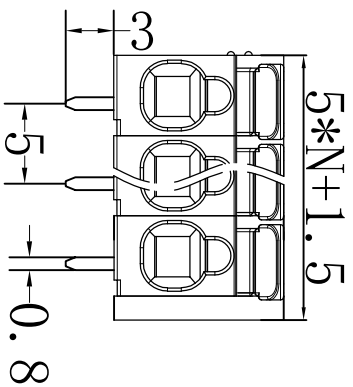

Linear dimension (Tolerances Standard GB/T 1486-2008)

variable range	to	over	to	over	to	over	to	over	to	over	to	over	to	over	to
±0.20	±0.30	±0.50	±0.70	±1.00	±1.30	±1.60	0.10	0.30	0.60	1.00	1.60	2.50	4.00	6.30	10.00

单位/UNITS	mm	尺寸/SIZE	A4	比例/SCALE	1:1	第三视角/THIRD ANGLE PROJECTION	版本/REV	V0
----------	----	---------	----	----------	-----	-----------------------------	--------	----

东莞市地安电子科技有限公司

名称/TITLE  
DA803R-500